

WATKINS-JOHNSON CO.  
PALO ALTO CALIFORNIA

BULK RATE  
U.S. POSTAGE  
PAID  
PERMIT NUMBER  
317  
SUNNYVALE  
CALIFORNIA

# Miniature X-band Amplifiers and Down Converters

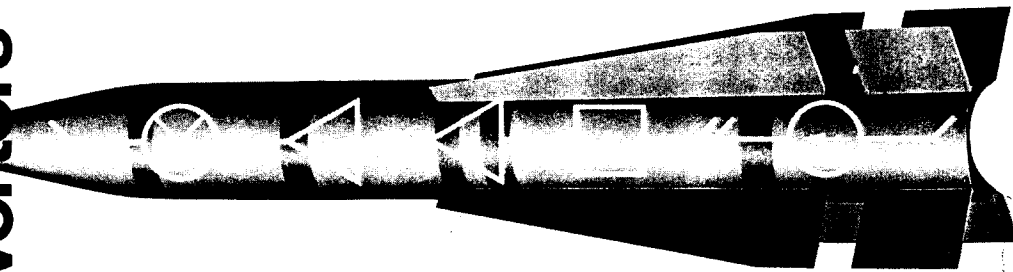

## Manufacturing and Office Locations

### United States

#### SALES OFFICES

**CALIFORNIA**  
Watkins-Johnson  
3333 Hillview Avenue  
Palo Alto 94304  
Telephone: (415) 493-4141

Watkins-Johnson  
2525 North First Street  
San Jose, 95131  
Telephone: (408) 262-1411

Watkins-Johnson  
831 South Douglas Street  
Suite 131  
El Segundo 90245  
Telephone: (213) 640-1980

#### DISTRICT OF COLUMBIA

Watkins-Johnson  
700 Quince Orchard Road  
Gaithersburg, Md 20760  
Telephone: (301) 948-7550

#### FLORIDA

Watkins-Johnson  
325 Whooping Loop  
Allamonte Springs 32701  
Telephone: (305) 834-8840

### International

#### ITALY

Watkins-Johnson Italiana  
S.p.A.  
Piazza G. Marconi, 25  
00144 Roma-EUR  
Telephone: 59 45 54  
Telex: 63278  
Cable: WJROM-ROMA

#### GERMANY, FEDERAL REPUBLIC OF

Watkins-Johnson  
Manzingerweg 7  
8000 Muenchen 60  
Telephone: (089) 836011  
Telex: 529401  
Cable: WJDBM-MUENCHEN

#### UNITED KINGDOM

Watkins-Johnson  
Shirley Avenue  
Windsor, Berkshire, SL4 5JU  
Telephone: Windsor 69241  
Telex: 847578  
Cable: WJUKW-WINDSOR

#### MARYLAND

Watkins-Johnson  
700 Quince Orchard Road  
Gaithersburg 20760  
Telephone: (301) 948-7550

#### MASSACHUSETTS

Watkins-Johnson  
5 Militia Drive  
Suite 11  
Lexington 02173  
Telephone: (617) 861-1580

#### PENNSYLVANIA

Watkins-Johnson  
385 Lancaster Avenue  
Haverford 19041  
Telephone: (215) 896-5854

#### OHIO

Watkins-Johnson  
2500 National Road  
Suite 200  
Fairborn 45324  
Telephone: (513) 426-8303

#### TEXAS

Watkins-Johnson  
9216 Markville Drive  
Dallas 75243  
Telephone: (214) 234-5396

The Watkins-Johnson Tech-notes is a bi-monthly periodical circulated to educational institutions, engineers, managers of companies or government agencies, and technicians. Individuals may receive issues of Tech-notes by sending their subscription request on company letterhead, stating position and nature of business to the Editor, Tech-notes, Palo Alto, California. Permission to reprint articles may also be obtained by writing the Editor.

## FET Amplifier Design

The goal of the amplifier development effort has been to achieve an amplifier module or "building block" of the most general applicability for X-band receiver front ends. It was therefore decided to design a low-gain unit with about 15-dB gain — an amount adequate to substantially reduce noise figure, while having minimum impact on dynamic range. Such an amplifier will typically precede a mixer/IF-amplifier combination, which has about 9 dB noise figure. Assuming an amplifier noise figure of 3.5 dB, the 15-dB gain will cause overall noise figure to be 3.8 dB. A further increase in preamplifier gain makes little improvement in noise figure. However, assuming gain compression at high signal levels is limited by the IF amplifier, adding more RF preamplifier gain reduces receiver dynamic range directly by an amount equal to the gain increase.

Two amplifier block diagrams are shown in Figures 1A and 1B. The amplifier shown in Figure 1A consists of two balanced stages. Utilization of the balanced design has the advantage of moderately low input and output VSWR (1.5:1 max). Size is kept small because the quadrature hybrid couplers are fabricated as part of the thin-film microwave integrated circuit.

An alternative approach, shown in Figure 1B, utilizes a single-ended input stage and an input isolator. Input VSWR is superior (1.2:1), but the isolator causes a substantial size increase. The isolator/single-ended amplifier approach also provides a slight noise figure advantage (on the order of 0.2 dB). This improvement is due to the isolator loss (0.2 dB) being less than the quadrature coupler loss (0.4 dB), and because of practical amplifier alignment considerations. It is generally simpler to align the single transistor for minimum noise figure than it is for the two-transistor balanced configuration.

X-band receiver applications generally require RF preamplification and/or frequency conversion to a low intermediate frequency (IF). It is becoming increasingly common for such applications to require improved electrical performance as well as size and weight minimization. This article deals with two approaches to size reduction: component miniaturization, and component integration to reduce complexity caused by coaxial or waveguide interconnection.

The first component development effort reported is that of an RF preamplifier in a miniature hermetic package. This amplifier design, applicable to the 8- to 10-GHz frequency range, incorporates modern Gallium Arsenide Field Effect Transistors (FETs). The FET achieves excellent noise figure (typically 2.0-2.5 dB device noise figure at 10 GHz) and is easily incorporated into thin-film circuit realizations, which are relatively small when compared to conventional alternatives, such as traveling-wave tubes or parametric amplifiers. The FET amplifier discussed achieves 15 dB gain and less than 3.5 dB noise figure in a package which occupies less than five cubic centimeters.

Receiver designs often include an RF preamplifier followed by either an image-reject mixer or a filter and conventional-mixer combination. The image-reject mixer is preferred in that it offers reduced conversion loss. However, in the past, it has generally been bulky in its physical realization. Application of thin-film microwave integrated circuit techniques to the image-reject mixer problem has resulted in significant size reduction. This size reduction was sufficient to allow direct fabrication of an integrated unit which includes both an FET preamplifier and an image-reject mixer. The result is an active down converter or "front end" which is particularly suitable for airborne and missile applications due to the size reduction achieved.

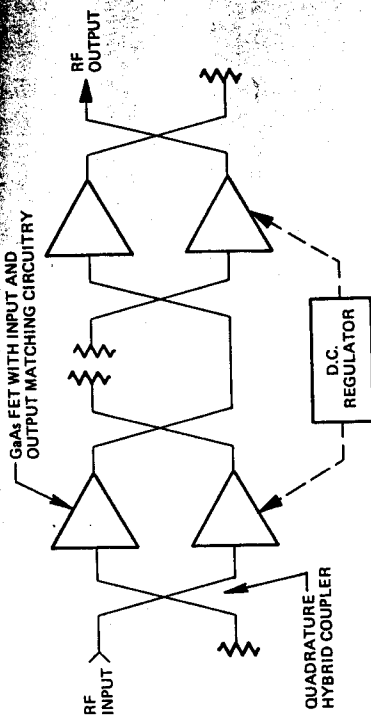

(NOTE: THE BALANCED DESIGN ASSURES LOW TERMINAL VSWR).

Figure 1A. Two-stage 8-10 GHz FET amplifier.

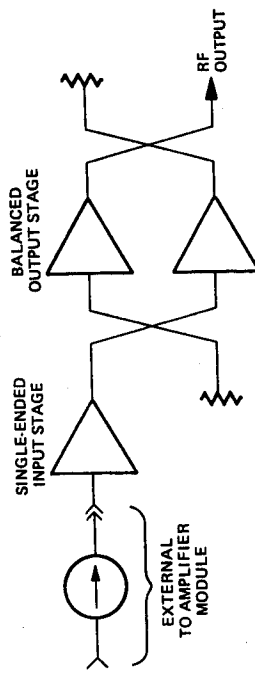

(NOTE: THE SINGLE-ENDED INPUT ACHIEVES MINIMUM NOISE FIGURE BUT REQUIRES AN EXTERNAL ISOLATOR FOR LOW INPUT VSWR).

Figure 1B. Two-stage 8-10 GHz FET amplifier.

The balanced two-stage amplifier is shown in Figure 2. Detailed electrical design techniques have been reported previously by Walker, et al. (see Reference 3). The gallium arsenide field effect transistors utilized are 0.5 micron gate length devices. These devices allow achievement of particularly low noise figure in X band.

The circuit is fabricated with transmission line elements formed by etch-



Figure 2. X-band FET two-stage amplifier in a hermetic module (WJ-1-minpac).

ing gold film... deposited on fused silica substrates. The lower dielectric constant of fused silica makes this material particularly suitable for realization of higher impedance transmission line elements, and interdigitated quadrature hybrids. As a result of the greater widths for high-impedance lines on fused silica, the discontinuities due to the sizes of the semiconductor devices used in the MIC designs are minimized. The lower propagation constant also reduces the electrical length of discontinuities by a factor of about 0.68. These characteristics are advantageous in the construction of phase-matched circuitry, as detailed in reference 2.

The amplifier shown in Figure 2 is unique in that it is enclosed in a small (2x4x0.5 cm) hermetic case, with pin electrical inputs. This case is hermetically sealed by seam-welding a thin Kovar lid to the case. The amplifier is shown in the case (without the lid), with the case mounted in a frame which secures coaxial input and output connectors. The case with input and output pins may alternatively be mounted directly in stripline circuitry, i.e., the amplifier may be integrated in a manner similar to that conventionally employed for diode switches and limiters.

Electrical performance of three balanced two-stage GaAs FET amplifiers is shown in Figure 3. Performance is reported for the 9.5-10.0 GHz range, although very similar results are achieved over any 500 MHz band between 8 and 10 GHz. Gain is typically 15 to 17 dB, and gain tracking error between units is less than 0.5 dB. Phase tracking error between units is less than  $\pm 7$  degrees. Noise figure is between 3.0 and 3.5 dB, and VSWR is typically 1.4:1. It is thus demonstrated that state-of-the-art performance has been achieved with significant miniaturization. As these new amplifier designs evolve from design to production status, improved phase and amplitude tracking ( $\pm 0.25$  dB and  $\pm 3$  degrees, typically) has resulted.

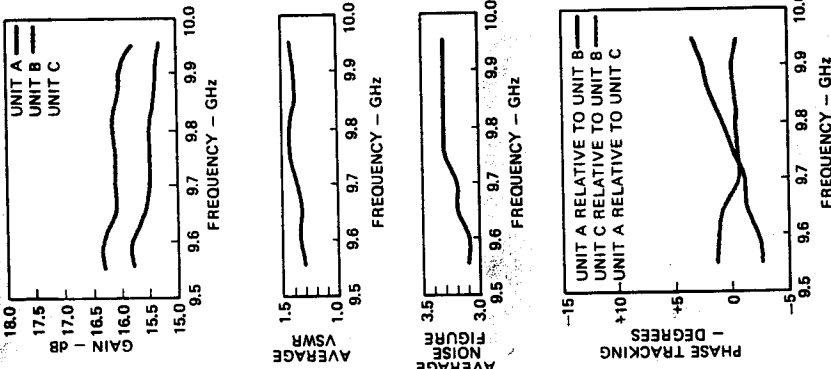

Figure 3. Summary of X-band minipac (WJ-5320-293) amplifier electrical performance.

The modular miniature package is particularly suitable for automated RF measurements and selection of matched amplifier sets.

### Front-End Design

A typical X-band receiver front-end design will involve a mixer following an input RF preamplifier. The development of small image-reject mixers (see Figure 4), has been pursued

12-18 GHz. A similar circuit has been optimized for the 8-10 GHz range, typically achieving 5-dB conversion loss and 20-dB image rejection. The design concepts have been reported by Cochrane and Marki (see reference 1).

A modular approach to a general X-band receiver front end was synthesized, as shown in Figure 5. Key to this concept is the inclusion of all active RF devices in a single hermetic package (identical to that of the amplifier shown in Figure 2). An input isolator was used to achieve minimum noise figure and low input VSWR. The active RF down converter module includes an input limiter, two-stage (one single-ended, one balanced) GaAs FET amplifier, and image-reject mixer (exclusive of the IF quadrature hybrid). The two mixer quadrature outputs are combined in an IF hybrid and then



Figure 4. Image-reject mixers are compatible with FET amplifiers.

with the objective of making these mixers compatible with the FET amplifiers. The mixers shown in Figure 4 cover 6-12 GHz, 8-16 GHz, and

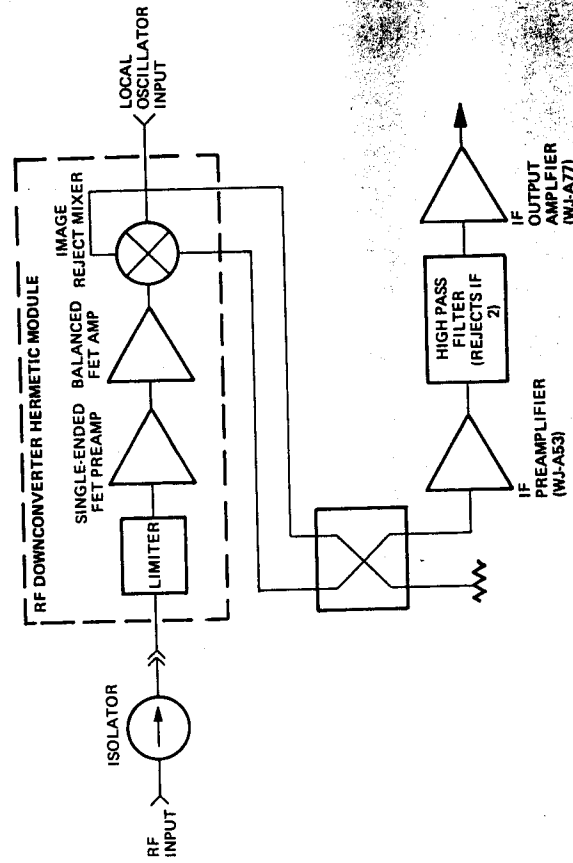

Figure 5. X-band front end block diagram.

regulator, and IF subassembly (all items shown in Figure 5). Additionally, there is a power divider for distribution of the local oscillator power to each channel.

Electrical performance for the three-channel, X-band integrated front end is shown in Figure 8. Of particular interest is the phase tracking between channels; it is  $\pm 8$  degrees over a 1-GHz

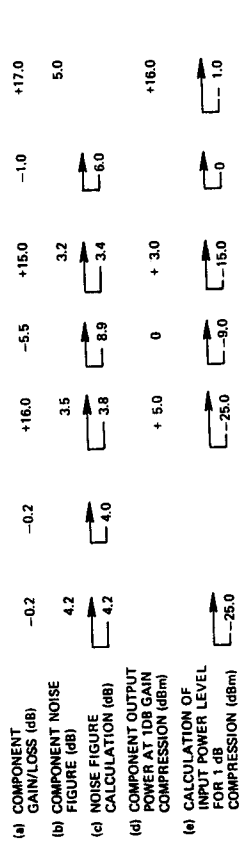

Figure 6. X-band front end electrical performance calculations.

fed to an IF preamplifier. The IF pre-amplifier and output amplifier are separated by a high-pass filter. For the particular IF that is chosen — 30 MHz, in this example — the high-pass filter rejects undesired signals at 15 MHz by at least 10 dB. Such an out-of-band 15-MHz signal may cause a second harmonic at the 30 MHz IF frequency in the output IF amplifier. The IF frequency is set by the IF quadrature hybrid and the high-pass filter, both of which are very easily changed. For example, a 60-MHz, 70-MHz, or 160-MHz IF are all equally straight forward. The IF amplifiers employed (WJ-A55 and WJ-A77) cover 5 to 500 MHz and thus do not limit the choice of IF frequency as long as it is below 500 MHz.

Calculation of electrical performance is presented in Figure 6. RF-to-IF gain is estimated to be 41 dB. Noise figure is dominated by the FET amplifier performance, and an overall noise figure of 4.2 dB is calculated. This is based on an assumed FET amplifier noise figure of 3.5 dB, for which experience indicates a 2.8- to 3.5-dB range, depending on FET quality.

### Front-End Performance

An integrated assembly of three receiver front-end channels are shown in Figure 7. The waveguide iso adapters dominate the mechanical layout. It is noted that these iso adapters could be replaced by coaxial isolators, or that isolators could be eliminated entirely in a coaxial design where a balanced FET amplifier is employed. The rectangular housings enclose the hermetic RF down converter module, dc

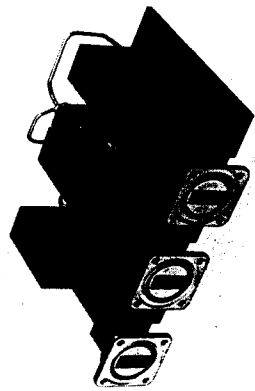

Figure 7. Three-channel X-band phase tracked radar front end (WJ-C81-2).

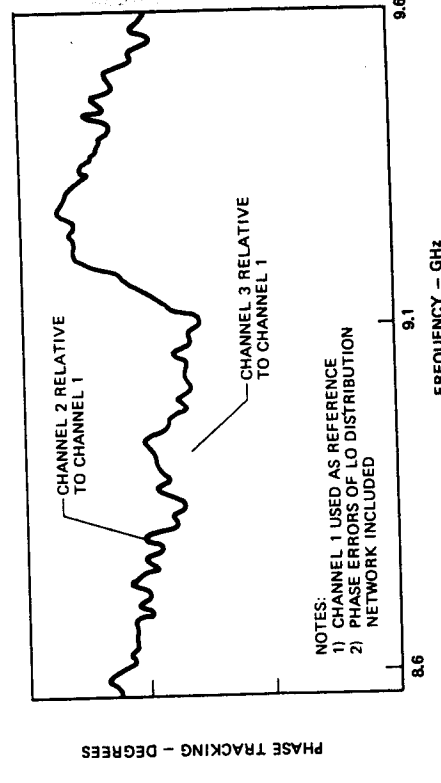
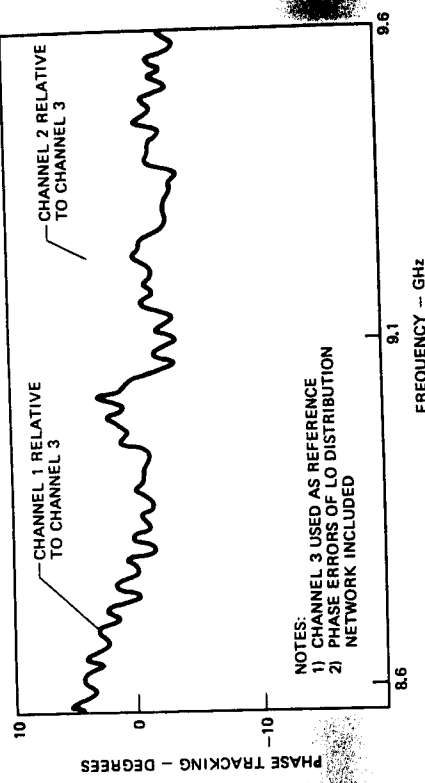

Figure 8. X-band front end phase tracking electrical performance.

have been presented in this article. Both involve construction of the active microwave circuits in a small hermetically sealed module. Electrical design emphasis has been on achieving low noise figure, and phase and gain tracking between multiple units. Amplifier noise figures of 3.5 dB maximum and receiver front-end noise figures of 4.2 dB maximum (at room temperature) have been demonstrated. Phase tracking of  $\pm 8$  degrees and gain tracking of 0.5 dB was achieved for a three-channel system over a 1-GHz bandwidth.

The output IF amplifier exhibits 1 dB gain compression at +18 dBm output power level, which, due to the RF-to-IF gain of 41 dB, translates to a -23 dBm input power level. Third-order intercept point is +30 dBm at the output, and -11 dBm relative to the input. These front ends thus offer relatively high dynamic range and low noise figure. This combination of relatively high dynamic range and low noise figure is a significant advantage of FET amplifiers over tunnel diode or parametric amplifiers.

Improved performance, reduced size and weight, and improved reliability have resulted from the overall integration of X-band radar receiver componentry. The front end described in this article has low noise figure combined with phase and gain tracking between units. The overall unit, including the waveguide adapter, is packaged in an area of less than ten cubic inches. New hermetic packaging technology is not only reducing the size of microwave components, but also improving their reliability. In addition, lower cost will result from the simpler construction techniques described for the MIC components.

the tracking properties of the converters. Phase tracking performance is dominated by the FET amplifier design.

RF-to-IF gain (shown in Figure 9) is between 41.7 and 43.3 dB, with gain tracking of about  $\pm 0.5$  dB. Noise figure varies between 3.5 dB and 4.2 dB, with an average of about 3.8 dB. This is about 0.5 dB higher than for an amplifier — an amount slightly less than predicted by calculations, apparently indicating a degree of conservatism in component performance estimates.

Measured dynamic range parameters include:

- (1) Input power for 1-dB gain compression . . . . . -23 dBm
- (2) Output third-order intercept point . . . . . +30 dBm
- (3) IF second-harmonic output intercept point . . . . . +50 dBm

The intermodulation products due to two signals with 0 dBm output level (for each signal) are at -60 dBm output level. The second order intercept point of +50 dBm was determined as follows: The signal level was adjusted for 0 dBm output and the LO frequency was adjusted for an IF output frequency of 30 MHz. The LO frequency was then changed such that the fundamental output response was at 15 MHz. The second harmonic content at 30 MHz was then measured to be below -50 dBm. Finally, dc current is 105 mA per channel, for a total of 315 mA at +15 volts.

### Conclusions

Two X-band designs, a miniature GaAs FET amplifier and an integrated RF amplifier/mixer-IF amplifier front end

bandwidth. This phase tracking is for the entire assembly, including errors introduced by the LO distribution power divider and cables. Phase tracking as opposed to match was measured — i.e., a constant offset in phase is calibrated out in the measurement. The phase and amplitude tracking between the three converters, presented in Figure 8, is similar to that observed for amplifiers. Consequently, it is concluded that the additional complexity of the mixer and IF components has an insignificant effect on

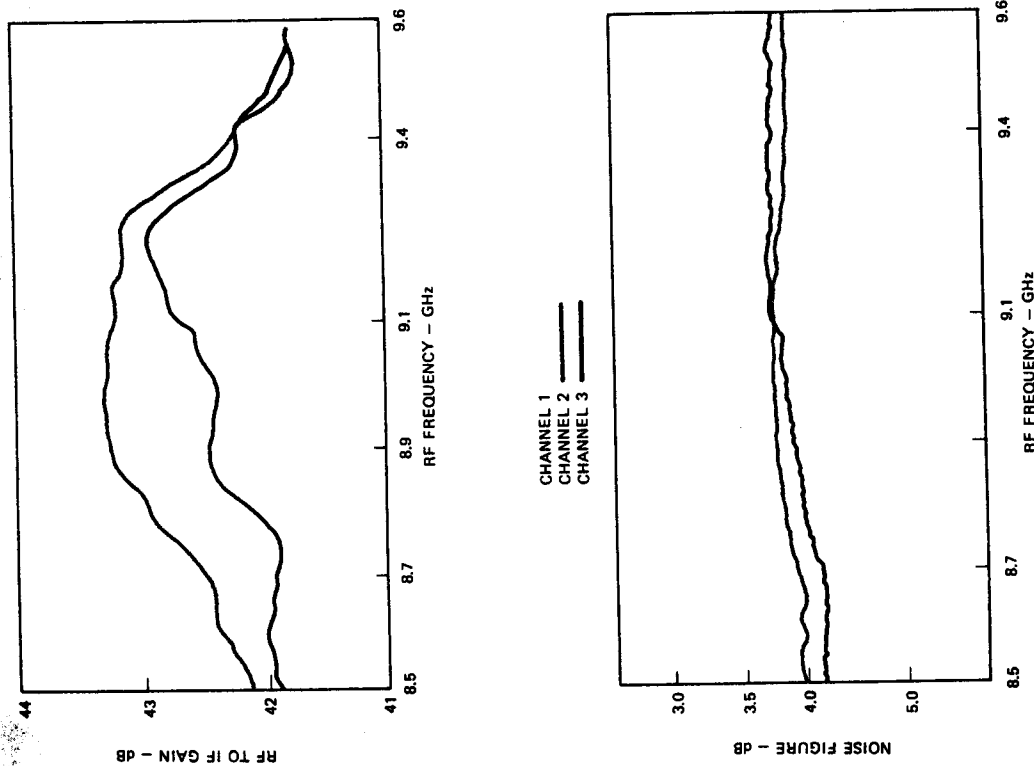

Figure 9. X-band front end RF-to-IF gain and noise figure performance.



## References

1. Cochrane, James B. and Ferenc A. Marki, "Thin-Film Mixers Team Up to Block Out Image Noise," *Microwaves*, Vol. 16, No. 3 (March 1977), pp. 34-40.
2. Crescenzi, E. James, Jr., Ferenc A. Marki, and W. Keith Kennedy, "Fused Silica: A Better Substrate for Mixers?" *Microwaves*, Vol. 15, No. 1 (January 1976).
3. Walker, Martin G., Ferenc A. Marki, and Howard A. Abramowitz, "MES FET Amplifiers Go to 18 GHz," *Microwave Systems News*, Vol. 6, No. 5 (May 1976).

## Authors:



### E. James Crescenzi, Jr.

Dr. Crescenzi is Manager of the Solid State R&D Department, Watkins-Johnson Solid State Devices Division. He is responsible for materials and selected circuit R&D activities. Materials research and development includes GaAs FET devices, transferred electron GaAs devices, ferrimagnetic materials, and thin-film microwave circuit processing and prototype services. Components development activities include integrated front-end design and product development, miniature low-noise GaAs FET amplifier development, thin-film microwave mixer product development, and advanced circuit analysis techniques.

Dr. Crescenzi, in addition to his management responsibilities, maintains a high level of activity in microwave

circuit design. Some of his achievements in the microwave field include the recent design of two narrowband low-noise FET amplifiers — a 2.8-dB noise figure, 9.6-10.0 GHz amplifier for radar application, and a 1.8-dB noise figure, 4.5-5.0 GHz amplifier for a communications application. He has designed five sophisticated mixer-filter sets covering higher microwave frequencies for application in ALQ-131 ECM equipment, and has also designed a novel 0.5 to 18-GHz mixer/converter which is central to the unique capabilities of the WJ-1840 microwave receiver system.

Dr. Crescenzi received a B.S. from the University of California and an M.S. and Ph.D. from the University of Colorado. He is a member of the IEEE, and is currently Treasurer of the Santa Clara Chapter of the Microwave Theory and Techniques Group.

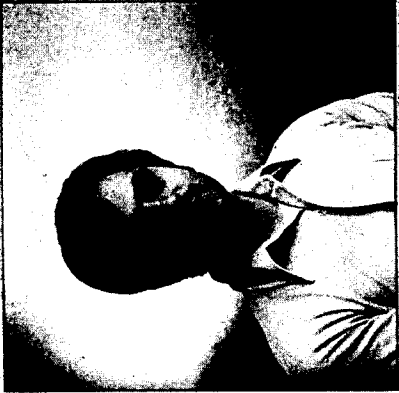

### Ferenc A. Marki

Mr. Marki is Head, Components R&D Section, Solid State Devices Division. He is responsible for the design and development of the broadband, microwave double-balanced mixers, FET amplifier/mixer front-ends, and miniature FET amplifiers. Mr. Marki has developed over fourteen new mixer products covering the frequency range of 0.4 to 18.5 GHz. These include the M12, M12A, and M19 — the microwave industry's first double-balanced mixers with up to 5 GHz IF bandwidth, and an ultra-wideband,

bridge-type, biasable, single-balanced mixer that covers 0.4 to 18.5 GHz.

Mr. Marki has also conceived and developed the "flatpack" line of integrable, miniaturized double-balanced mixers in the 2.5- to 18.5-GHz range (the M15-M18 mixers). These mixers provide state-of-the-art conversion loss (5 to 5.5 dB at mid-band) in a small package which can be directly integrated with other microwave integrated circuit (MIC) assemblies.

Mr. Marki holds a B.S.E.E. from the University of California, Berkeley, and is a member of the IEEE.